

## CARR® Centritech Separation Systems U2k® Single Use Centrifuge



### Features

- Maximum flow rate up to 20 l/min\* (5 times flow rate of UniFuge)
- Variable g-force up to 3000 x g\*
- Capability to clarify up to 2000 liters cell cultures in 8 hours or less\*
- Continuous discharge of supernatant and cell culture reduces operation time
- Low weight of empty separation module after separation
- Compact footprint and height of centrifuge
- Easily movable with stainless steel casters
- Low noise level
- Optional data acquisition for SCADA System

\*process dependant

# CARR®Centritech Separation Systems U2k® Single Use Centrifuge

CARR® Centritech's® new U2k® from PneumaticScaleAngelus® is the scaled-up version of our successful UniFuge® single use centrifuge. It utilizes a gamma irradiated, single-use module that requires NO CIP and NO SIP. All process contact surfaces are supplied as one module and 100% replaceable after each run. U2k® modules are readily tube welded to your single-use bioreactor connections (customer-specified single-use connectors available upon request). The U2k® is completely automated with flexible cycle parameter entry via touch screen HMI. The feed suspension is gently pumped to the module and the cells settle to the outer radius while the clear supernatant and concentrate are continuously discharged.

## U2k® Technical Specifications

- Footprint 80cm x 206cm x 200cm high (31" x 81" x 78"high)
- Total skid weight of 1050 kg (2300 lbs.)
- Weight of empty Separation Disposable Module less than 13 kg (28 lbs)
- Allen Bradley® or Siemens® PLC
- Allen Bradley® or Siemens® HMI Touchscreen 30.7 cm (12.1")
- Clean Dry Air Supply 6 bar (90 psi) @ 1 SLPM
- Maximum Case Pressure (for cooling) 6.9 bar (100 psi)
- Three phase voltage supply:
  - US: 230V/60Hz, 80A or 460V/60Hz, 40A
  - Europe: 400V/50Hz, 46A
  - Japan: 200V/60Hz/50Hz, 90A
  - Others as needed

## Continuous Discharge Single Use Module

- Tapered rotor to transport cells
- Centripetal pump to evacuate cell paste
- Center feed for low shear operation
- Concentric tubes to introduce feed and remove supernatant and concentrate
- USP Class VI components
- Gamma irradiated

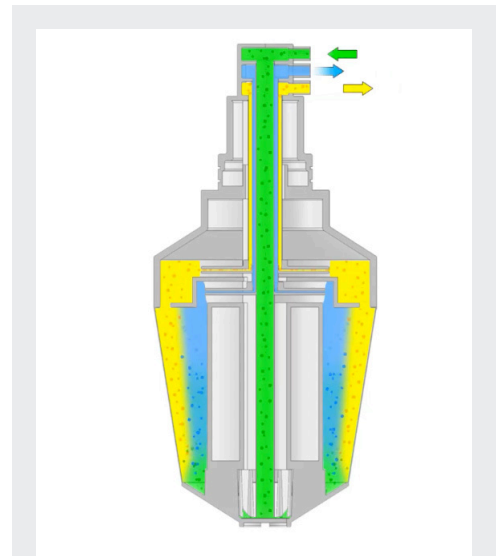

Continuous Separation & Discharge



Module Cutaway

For more information, please contact:

BioProcess Engineering Services Ltd

+44 (0) 1795 859 470

[info@bioprocess-eng.co.uk](mailto:info@bioprocess-eng.co.uk)

[www.bioprocess-eng.co.uk](http://www.bioprocess-eng.co.uk)

Angelus | Carr Centritech | Consolidated | Continental/Closetech | Hema  
Mateer Burt | Multi-Tech Systems | OnTrack | Zepf Change Parts

Pneumatic Scale Angelus

4485 Allen Road  
Stow, OH 44224 USA

t. +1 (330) 923-0491  
[psangelus.com](http://psangelus.com)

barrywehmler  
**bw**  
betterworld